

PRIMETIME

PRIMETIME STAINLESS STEEL CENTRIFUGAL PUMP INSTALLATION, OPERATION, AND REPAIR MANUAL

The PRIMETIME is a high performance self-priming stainless steel centrifugal pump. The pump is ideal for marine, industrial, agricultural or commercial applications where suction lift is required. This model features all 316 stainless steel components for superior corrosion resistance when pumping chemical compounds. A carbon / ceramic / viton bellows seal is standard. Ports are 3/4" with 1/8" NPT fill port. The PRIMETIME model is capable of 12 foot suction lift (3450 rpm)
Weight: 16 lbs

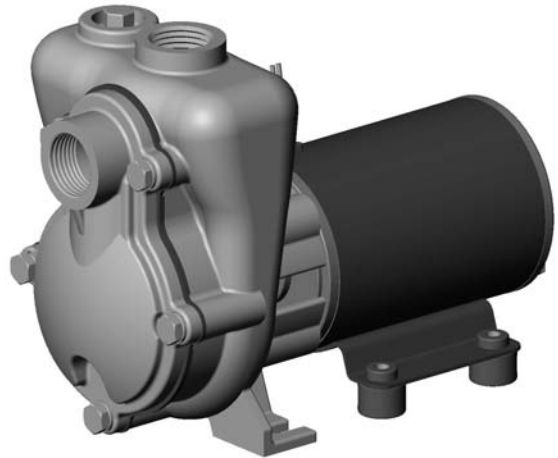

GENERAL SAFETY INFORMATION:

THE FOLLOWING WARNINGS ARE USED TO NOTIFY AND ADVISE THE USER OF THIS PRODUCT OF PROCEDURES THAT MAY BE DANGEROUS TO THE USER OR RESULT IN DAMAGE TO THE PRODUCT.

THIS BULLETIN MUST BE READ COMPLETELY BEFORE INSTALLING, OPERATING OR SERVICING THE PUMP.

- **DO NOT** perform service or maintenance when the pumping system is pressurized. Injury or death may occur.
- **DO NOT** operate the pump in a manner that it was not intended to be used.
- **DO NOT** mount the pump such that high piping loads exist on the pump flanges, or in a rigid piping system that does not allow the pipe to expand and cause the pump to be strained.
- **DO NOT** use bronze or brass fittings.
- **DO NOT** continue to operate the pumping system when a known leak exists.
- **DO NOT** continue to operate the pump when unusual noise or vibration occurs.
- **DO NOT** operate beyond the pressure or temperature limits stated in the product literature.
- **DO NOT** allow severe temperature changes to occur in a short time period within the pumping system.

INSTALLATION:

For optimum performance, place the pump as close to the liquid as possible to minimize suction lift. For best results, the pump should be installed no more than 10 feet above the liquid supply. The motor is splash resistant, not submersible, and should be located in a dry environment.

www.primetimpump.com

For Warranty: www.primetimpump.com/datasheets/primetime_warranty.pdf

PIPING/MOUNTING:

The pump inlet and outlet has 3/4" pipe connections. Use pipe sealant on the threads and other connections. The base does not require direct mounting if one of the pipe flanges is rigid mounted. Do not rigid mount both the flanges and the base to avoid mounting tolerances that may distort the motor base. Install the pump with the shaft in a horizontal direction. Never install the pump vertical with the motor below the pump.

ELECTRICAL:

The motor must be protected from over current by using a fuse or circuit breaker (see chart below for correct protection). The proper minimum wire size is stated for each voltage application. Make sure that the pump has the proper voltage rating to match the installation power. Do not use or install if the voltage on the label is different than the installation. All wire connections must be secure and sealed to protect against arcing. Pump must be ground and bonded. Follow all local installation codes.

MOTOR VOLTAGE ON NAME PLATE	FUSE/CB AMPS	WIRE SIZE AWG
12VDC	15	14
24VDC	10	16
115/230VAC	2.0/1.1	18

NOTE: Dual voltage motors are shipped set to low (115 V) voltage. To change, open conduit cover and set to high (230 V) voltage then cut plug off of cord.

OPERATION:

The PRIMETIME is a self-priming centrifugal pump and only requires priming prior to its initial start-up. This is accomplished by removing the priming plug and filling the chamber with liquid. The pump will retain sufficient liquid for self-priming thereafter.

REPAIR AND MAINTENANCE:

DC motor brush life expectancy is 6,000 hours total brush life. The motor is not rebuildable after the brushes have worn to the limits.

The pump has a carbon/ceramic seal that may last several thousand hours based upon the application. If the motor is replaced, the mechanical shaft seal should also be replaced. A seal that leaks will show leakage through the slot between the pump housing and the motor. Extreme leakage may damage the motor bearings and contaminate the inside of the motor.

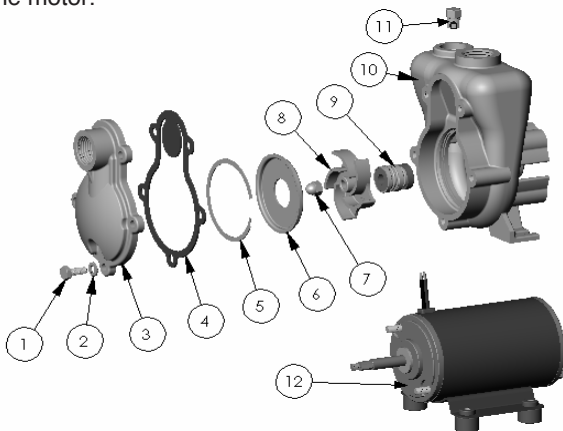

DISASSEMBLY:

1. Remove five cover screws and remove the cover and gasket.
2. Remove snap ring and wear plate.
3. Secure the impeller and remove the impeller lock nut. Pull the impeller straight out off the motor shaft.
4. Remove the seal-rotating portion by pulling the seal off by hand.
5. Remove the two capscrews that hold the pump housing onto the motor. Remove the pump housing and push the seal seat out using a screwdriver.

INSPECT PUMP PARTS:

Always replace the mechanical seal. Check the seal for dry run wear or damage. Check the motor shaft for wear at the secondary sealing surface from the mechanical seal. If worn, replace the motor. Check the motor bearings by rotating the motor by hand. If the shaft rotation is not smooth or has radial/axial endplay, replace the motor. Check the impeller running surface between the impeller and cover. If the surfaces are worn or irregular, replace each item.

Clean the parts that are to be reused using a solvent or mild cleaner. Remove abrasive material.

REASSEMBLY:

1. Press the new seal seat into the pump housing. A light lubricant may be used to aid the assembly. Install the pump housing onto the motor and fasten the screws through the motor.
2. Install the rotating portion of the mechanical seal by sliding the seal over the motor shaft. Do not use any lubricant.
3. Place the impeller onto the shaft over the "D" drive against the shoulder and tighten the impeller lock nut until the impeller is securely shouldered on the motor shaft. Thread locking grade Loctite should be used to secure the nut.
4. Replace wear plate and snap ring. Check the pump for internal interference by rotating the impeller. The pump should rotate freely with only seal friction.
5. Install the gasket and cover onto housing and fasten with capscrews and lockwashers.

ITEM NO.	PART NO.	DESCRIPTION	QTY.
1	35039	CAPSCREW - 316 S.S. - 1/4-20 X 5/8	5
2	33564	LOCKWASHER - 316 S.S. - 1/4	5
3	35024	COVER - 316SS MACH.	1
4	35025	GASKET - VITON 70 DUROMETER	1
5	35027	RETAINING RING - 316SS	1
6	35026	WEAR PLATE - 316SS	1
7	28766	ACORN NUT - 316SS	1
8	34033	IMPELLER - 316SS	1
9	34038	MECHANICAL SEAL - VITON	1
10	35022	HOUSING - 316SS MACH.	1
11	21255	PIPE PLUG - 1/8" NPT 316SS	1
12		EL. MOTOR - SPECIFY	1

www.primetimpump.com

For Warranty: www.primetimpump.com/datasheets/primetime_warranty.pdf